

A multipurpose Hopf deformation of the Algebra of Feynman-like Diagrams

G H E Duchamp^a, A I Solomon^{c,d}, P Blasiak^b, K A Penson^c and A Horzela^b

^a Institut Galilée, LIPN, CNRS UMR 7030
99 Av. J.-B. Clement, F-93430 Villetaneuse, France

^b H. Niewodniczański Institute of Nuclear Physics
Polish Academy of Sciences
ul. Eliasza-Radzikowskiego 152, PL 31342 Kraków, Poland

^c Laboratoire de Physique Théorique de la Matière Condensée
Université Pierre et Marie Curie, CNRS UMR 7600
Tour 24 - 2ième ét., 4 pl. Jussieu, F 75252 Paris Cedex 05, France

^e The Open University, Physics and Astronomy Department
Milton Keynes MK7 6AA, United Kingdom

Abstract. We construct a three parameter deformation of the Hopf algebra **LDIAG**. This new algebra is a true Hopf deformation which reduces to **LDIAG** on one hand and to **MQSym** on the other, relating **LDIAG** to other Hopf algebras of interest in contemporary physics. Further, its product law reproduces that of the algebra of polyzeta functions.

1 Introduction

The complete journey between the first appearance of a product formula by Bender et al. [1] and their related Feynman-like diagrams to the discovery of a Hopf algebra structure [8] on the diagrams themselves, goes roughly as follows.

Firstly, Bender, Brody, and Meister [1] introduced a special field theory which proved to be particularly rich in combinatorial links and by-products [11] (not to mention the link with vector fields and one-parameter groups [7, 10]).

Secondly, the Feynman-like diagrams of this theory label monomials which combine naturally in a way compatible with monomial multiplication and co-addition (i.e. the standard Hopf algebra structure on the space of polynomials). This is the Hopf algebra **DIAG** [8]. The (Hopf-)subalgebra of **DIAG** generated by the primitive graphs is the Hopf algebra **BELL** described in Solomon's talk at this conference [12].

Thirdly, the natural noncommutative pull-back of this algebra, **LDIAG**, has a basis (the *labelled* diagrams) which is in one-to-one correspondence with that of the *Matrix Quasi-Symmetric Functions* [13] (the *packed matrices* of **MQSym**), but their algebra and co-algebra structures are completely different. In particular, multiplication in **MQSym** involves a sort of shifted shuffle

with overlappings reminiscent of Hoffmann's shuffle used in the theory of polyzeta functions [2]. The superpositions and overlappings involved there are not present in (non-deformed) **LDIAG** and, moreover, the coproduct of **LDIAG** is co-commutative while that of **MQSym** is not.

The aim of this paper is to announce the existence of a Hopf algebra deformation which connects **LDIAG** to other Hopf algebras relevant to physics (Connes-Kreimer, Connes-Moscovici, Brouder-Frabetti, see [6]) and other fields (noncommutative symmetric functions, Euler-Zagier sums).

ACKNOWLEDGEMENTS : The authors would like to thank Jim Stasheff, Christophe Tollu and Loïc Foissy for fruitful interactions.

2 Labelled Diagrams and Diagrams

Product formula involves a summation over all diagrams of a certain type [12] a labelled version of which is described below.

Labelled diagrams can be identified with their weight functions which are mappings $\omega : \mathbb{N}^+ \times \mathbb{N}^+ \rightarrow \mathbb{N}$ such that the supporting subgraph

$$\Gamma_\omega = \{(i, j) \in \mathbb{N}^+ \times \mathbb{N}^+ \mid w(i, j) \neq 0\} \quad (1)$$

has specific projections i.e. $pr_1(\Gamma_\omega) = [1..p]$; $pr_2(\Gamma_\omega) = [1..q]$ for some $p, q \in \mathbb{N}$ (notice that when one of p, q is zero so too is the other and the diagram is empty).

These graphs are represented by labelled diagrams as follows

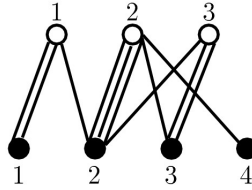

The labelled diagrams form the set **ldiag** and prescribe monomials through the formula $\mathbb{L}^{\alpha(d)} \nabla \beta(d)$ where $\alpha(d)$ (resp. $\beta(d)$) is the “white spot type” (resp. the “black spot type”) i.e. the multi-index $(\alpha_i)_{i \in \mathbb{N}^+}$ (resp. $(\beta_i)_{i \in \mathbb{N}^+}$) such that α_i (resp. β_i) is the number of white spots (resp. black spots) of degree i (i lines connected to the spot).

There is a (graphically) natural multiplicative structure on **ldiag** such that the arrow

$$m_{(\mathbb{L}, \nabla)} : d \mapsto \mathbb{L}^{\alpha(d)} \nabla \beta(d) \quad (2)$$

is a morphism.

It is clear that one can permute black spots, or white spots, of d without changing the monomial $\mathbb{L}^{\alpha(d)} \nabla \beta(d)$. The classes of (labelled) diagrams up to this equivalence (permutations of white - or black - spots among themselves) are naturally represented by unlabelled diagrams and will be denoted **diag** (including the empty one).

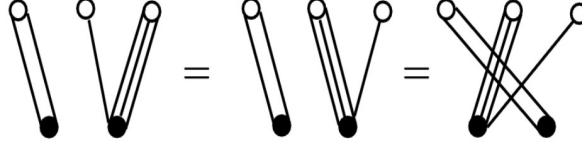

For both types of diagram the product consists of concatenating the diagrams i.e. placing d_2 on the right of d_1 [8] (the result, for d_1, d_2 , will be denoted $[d_1|d_2]_D$ in **diag** and $[d_1|d_2]_L$ in **ldiag**). These products endow **diag** and **ldiag** with the structure of monoids, with the empty diagram as neutral element. The corresponding commutative diagram is as follows (where X^2 means the cartesian square of the set X).

$$\begin{array}{ccccc}
 \text{Labelled diagrams}^2 & \xrightarrow{\text{Unlabelling}^2} & \text{Diagrams}^2 & \xrightarrow{m_{(\mathbb{L},\mathbb{V})} \times m_{(\mathbb{L},\mathbb{V})}} & \text{Monomials}^2 \\
 \text{product} \downarrow & & \text{product} \downarrow & & \text{product} \downarrow \\
 \text{Labelled diagrams} & \xrightarrow{\text{Unlabelling}} & \text{Diagrams} & \xrightarrow{m_{(\mathbb{L},\mathbb{V})}} & \text{Monomials}
 \end{array} \quad (3)$$

It is easy to see that the labelled diagram (resp. diagrams) form free monoids. We denote by **DIAG** and **LDIAG** the K -algebras of these monoids [8] (K is a field).

One can shuffle the product in **ldiag**, counting crossings and superpositions. The definition of the deformed product is expressed by the diagrammatic formula

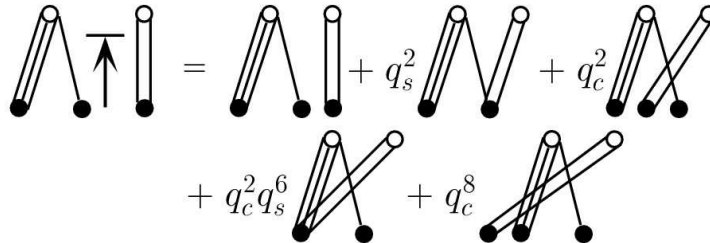

and the descriptive formula below.

$$[d_1|d_2]_{L(q_c, q_s)} = \sum_{\substack{cs([d_1|d_2]_L) \\ \text{are all crossing and} \\ \text{superpositions of black spots}}} q_c^{nc \times \text{weight}_2} q_s^{\text{weight}_1 \times \text{weight}_2} cs([d_1|d_2]_L) \quad (4)$$

where

- q_c, q_s are coefficients in K

- the exponent of $q_c^{nc \times weight_2}$ is the number of crossings of “what crosses” times its weight
- the exponent of $q_s^{weight_1 \times weight_2}$ is the product of the weights of “what is overlapped”
- terms $cs([d_1|d_2]_L)$ are the diagrams obtained from $[d_1|d_2]_L$ by the process of crossing and superposing the black spots of d_2 on those of d_1 , the order and identity of the black spots of d_1 (resp. d_2) being preserved.

What is striking is that this law (denoted above $\hat{\uparrow}$) is associative. Moreover, it can be shown [3, 4] that this process decomposes into two transformations: twisting and shifting. In fact, specialized to certain parameters, this law is reminiscent of others [2].

Parameters	(0,0) (shifted)	(1,1) (shifted)	(1,1) (unshifted)
Laws	LDIAG	MQSym	Hoffmann & Euler-Zagier

3 Hopf Deformation

Using a total order on the monomials of **ldiag**, it can be shown that the algebra **LDIAG**(q_c, q_s) is free. Thus one may construct a coproduct Δ_t ; $t \in K$ such that **LDIAG**(q_c, q_s, t) = (**LDIAG**(q_c, q_s), $1_{\mathbf{ldiag}}, \Delta_t, \varepsilon, S$) is a Hopf algebra. We have the following specializations

$$\frac{(q_c, q_s, t)}{\simeq} \parallel \begin{array}{|c|c|} \hline (0,0,0) & (1,1,1) \\ \hline \mathbf{LDIAG} & \mathbf{MQSym} \\ \hline \end{array}$$

4 Conclusion

The results which we announced here in this note can be illustrated by the following picture. All details will be given in forthcoming papers [3, 4].

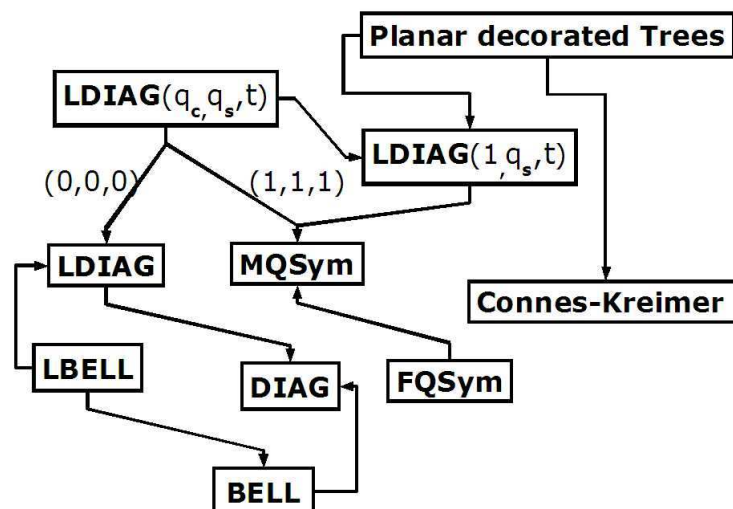

References

- [1] C. M. BENDER, D. C. BRODY, AND B. K. MEISTER, *Quantum field theory of partitions*, J. Math. Phys. **40** (1999)
- [2] P. CARTIER, *Fonctions polylogarithmes, nombres polyzêtas et groupes pro-unipotents*, Séminaire Bourbaki, Mars 2001, 53ème année, 2000-2001, **885**
- [3] G. H. E. DUCHAMP, G. KOSHEVOY, K. A. PENSON, C. TOLLU, F. TOUMAZET, *Geometric combinatorial twisting and shifting*, Séminaire Lotharingien (in preparation).
- [4] G. H. E. DUCHAMP, A.I. SOLOMON, P. BLASIAK, A. HORZELA AND K.A. PENSON, *The Hopf Algebra of Feynman-like Diagrams : Twisting and Shifting*. (in preparation)
- [5] L. FOISSY, *Isomorphisme entre l'algèbre des fonctions quasi-symétriques libres et une algèbre de Hopf des arbres enracinés décorés plans*, personal communication.
- [6] L. FOISSY, *Les algèbres de Hopf des arbres enracinés décorés*, PhD Memoir, Reims University (2002).
- [7] G. DUCHAMP, A.I. SOLOMON, K.A. PENSON, A. HORZELA AND P. BLASIAK, *One-parameter groups and combinatorial physics*, Proceedings of the Symposium Third International Workshop on Contemporary Problems in Mathematical Physics (COPROMAPH3) (Porto-Novo, Benin, Nov. 2003), J. Govaerts, M. N. Hounkonnou and A. Z. Msezane (eds.), p.436 (World Scientific Publishing 2004). arXiv: quant-ph/04011262
- [8] G. H. E. DUCHAMP, P. BLASIAK, A. HORZELA, K. A. PENSON, A. I. SOLOMON, *Feynman graphs and related Hopf algebras*, J. Phys: Conference Series (30) (2006) 107, Proc of SSPCM'05, Myczkowce, Poland. arXiv : cs.SC/0510041
- [9] A. HORZELA, P. BLASIAK, G. DUCHAMP, K. A. PENSON AND A.I. SOLOMON, *A product formula and combinatorial field theory*, Proceedings of the XI International Conference on Symmetry Methods in Physics (SYMPHYS-11) (Prague, Czech Republic, June 2004), C. Burdik, O. Navratil, and S. Posta (eds.) (JINR Publishers, Dubna). arXiv:quant-ph/0409152
- [10] P. BLASIAK, A. HORZELA, K. A. PENSON, G. H. E. DUCHAMP, A.I. SOLOMON, *Boson normal ordering via substitutions and Sheffer-Type Polynomials*, Phys. Lett. A **338** (2005) 108
- [11] P. BLASIAK, K. A. PENSON, A.I. SOLOMON, A. HORZELA, G. H. E. DUCHAMP, *Some useful formula for bosonic operators*, J. Math. Phys. **46** 052110 (2005).
- [12] A.I. SOLOMON, G. H. E. DUCHAMP, P. BLASIAK, A. HORZELA, K. A. PENSON, *Hopf Algebra Structure of a model Quantum Field Theory*, This volume.
- [13] G. DUCHAMP, F. HIVERT, J. Y. THIBON, *Non commutative functions VI: Free quasi-symmetric functions and related algebras*, International Journal of Algebra and Computation Vol 12, No 5 (2002).